



丹麦 Denmark  
EXPO 2010

# GRUNDFOS DATA BOOKLET

## DWK 和 DPK泵 0.75 to 90 kW 50 Hz



BE > THINK > INNOVATE >

GRUNDFOS 

DPK特点 .....	3
介绍 .....	4-6
简介 .....	4
应用 .....	4
介质 .....	4
安装深度 .....	4
电机 .....	4
电缆 .....	4
结构特点 .....	4
运行条件 .....	5
型号说明 .....	6
变形产品列表/主要部件材质表 .....	7
性能曲线 .....	8-9
DPK性能曲线.....	8
DWK.E性能曲线.....	8
DWK.O性能曲线 .....	9
尺寸.....	10-13
DPK尺寸 .....	10
DWK.O尺寸.....	12
DWK.E尺寸 .....	13
附件.....	14-19
DPK附件 .....	14
DWK附件.....	16

# DPK特点

## 易维护油栓

可监视油箱中油的状况，从而方便进行维护和服务

## 法兰或软管连接

取决于你的要求，需和泵同时订购软管或者法兰连接

## 自藕安装或者移动式安装

灵活的潜水安装选择，增大了其功能性

## 电机保护

内置的双金属传感器防止过热

## 轴封

双机封放置在油箱中以确保无故障运行

## 高效叶轮

球墨铸铁叶轮给予了其高效性，延长了其寿命

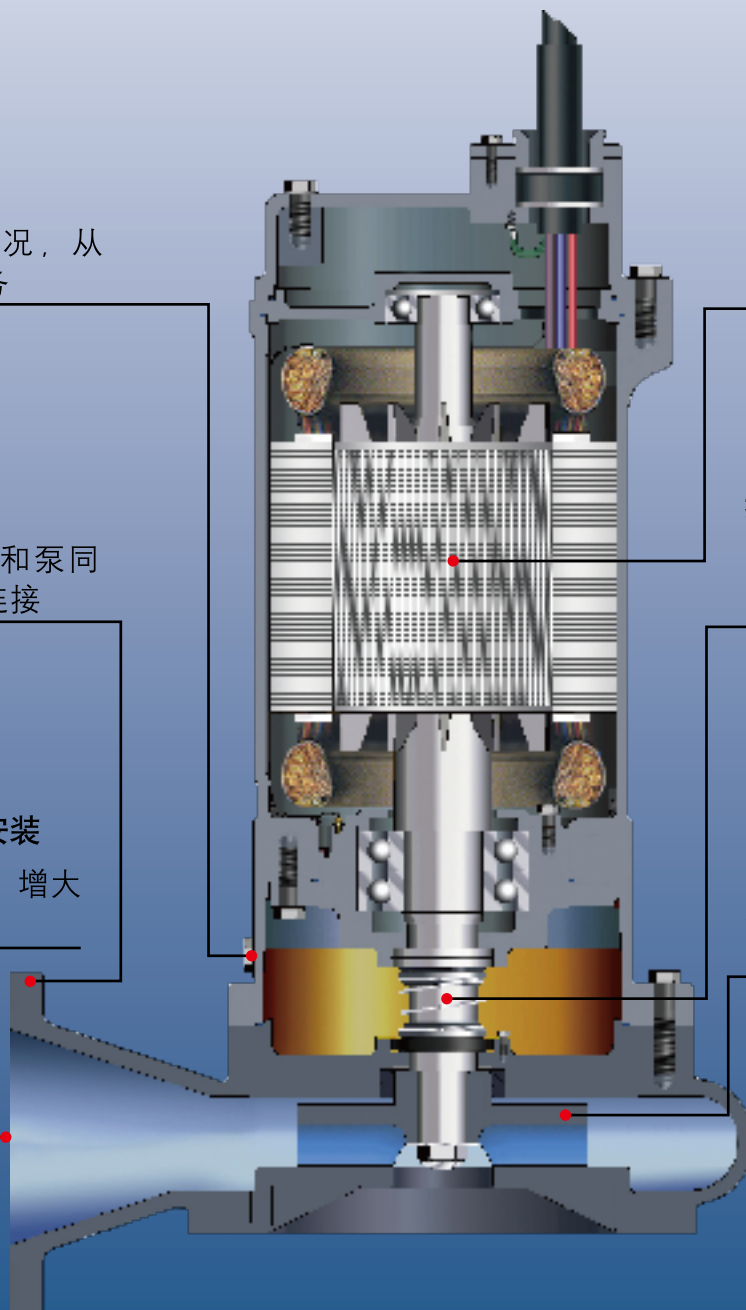

## 简介

本样本适用于格兰富工程排水泵和排水泵DWK和DPK。



图1. DWK/DPK移动式安装形式

DWK/DPK的叶轮有半开式和闭式两种形式，用于打排水、建筑及工业地表水等。

DWK/DPK采用耐腐蚀材料，如球铁和高铬不锈钢。配置2极电机，功率0.75~90kW，允许10~20mm固体通过。

DWK/DPK的安装形式有两种：

- 1、潜水移动式安装(DWK/DPK)
- 2、潜水自耦安装(DPK)

## 应用

DWK/DPK适用于以下应用：

- 排水
- 地表水
- 地下水
- 含磨蚀性杂质的水(DWK)

适用场合：建筑、地下车库、工地、低洼雨水集水区、流程工业水等。

如下表格为DWK/DPK使用场合表，仅供参考。

应用	DWK		DPK
	O	E	
地下水	x	x	x
排水和地表水	x	x	x
含微粒的地表水和排水			x
有磨损性的地表水	x	x	
无颗粒和纤维的工业流程水	x	x	x

## 介质

PH值：4~10

温度：0°C~40°C

当输送介质的密度、粘度高于水时，需加大电机。

## 安装深度

最深至液面以下25m。

## 电机

电机为完全封闭式的防水电机。

绝缘等级：F(155°C)

温升等级：F(105°C)

防护等级：IP68

## 电缆

电缆长度标准为10m，电缆规格另询格兰富，其他长度可供，见变形产品列表。

## 结构特点

DWK/DPK采用双机封的设计，并将其置于油腔中以确保无故障运行。

DWK入口有过滤网，仅用于移动式安装。

如果需要，DPK/DWK均可根据客户工作点切割叶轮。

## DWK出口连接

一般采用软管或法兰连接。



图2. DWK出口连接方式



## DPK出口连接

一般采用法兰连接和自耦连接，或作为变形产品采用软管连接。

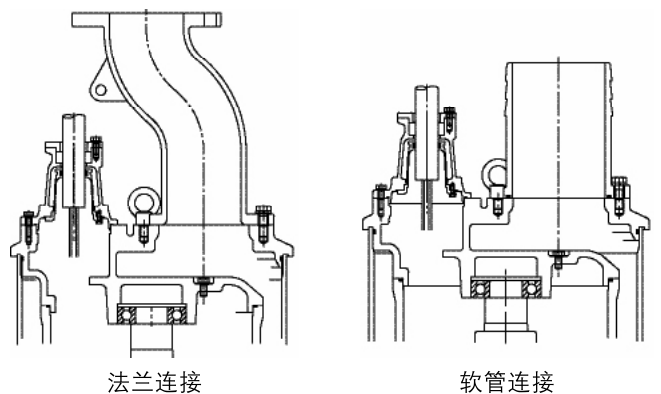
座环、弯管或自耦需另外采购(标准配置时，DPK泵 $\leq 2.2\text{kW}$ 配置有座环， $\geq 3.7\text{kW}$ 不配置座环)。



图3. DPK出口连接方式

## DWK.O

- 防水电缆入口可阻止液体进入电机
- 无需另外的传感器电缆
- 配有双金属的热传感器用于电机过热保护，除了以下型号为内置三相热保护器用于电机过热保护  
DWK.O.x.x.075.x.x.R  
DWK.O.x.x.15.x.x.R  
DWK.O.x.x.22.x.x.R  
DWK.O.x.x.37.x.OD.R
- 泄漏传感器可持续检测电机腔体是否进水，除了以下型号  
DWK.O.x.x.075.x.x  
DWK.O.x.x.15.x.x  
DWK.O.x.x.22.x.x  
DWK.O.x.x.37.x.x
- 顶部出水口的设计使其结构紧凑
- 对R型泵，高铬不锈钢叶轮和不锈钢滤网，增强了水泵的抗磨蚀能力
- 双机封(SiC-SiC)可用于重载条件
- 高效电机使其具有高稳定性和低运行成本

## DWK.E

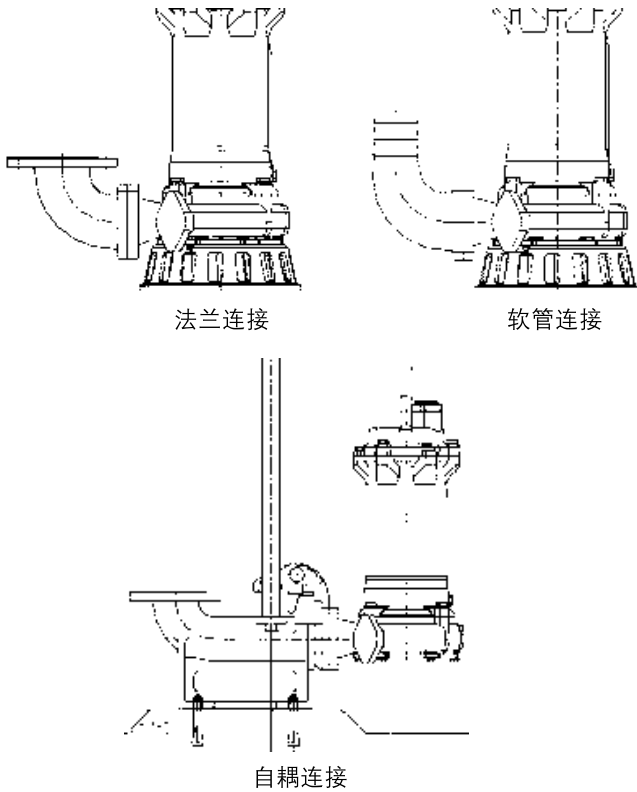
- 三芯电缆入口组件含一个环氧隔膜式橡胶圈和一个橡胶盖确保其防水性
- 无需另外的传感器电缆，除了以下型号：  
DWK.E.x.x.75.x.x.x  
DWK.E.x.x.90.x.x.x
- 配有双金属热传感器用于电机过热保护
- 泄漏传感器可持续检测电机腔体是否进水
- 顶部出水口的设计使其结构紧凑
- 电机冷却套有助于电机冷却并促使水泵最低允许运行液位降低到了入口过滤器的顶部
- 对R型泵，高铬不锈钢叶轮和不锈钢滤网，增强了水泵的抗磨蚀能力
- 三密封系统包括一个置于油箱中的双机封(SiC-SiC)和一个唇形密封，可承受高压
- 高效电机使其具有高稳定性和低运行成本

## DPK

- 防水电缆接口可阻止液体进入电机
- 无需另外的传感器电缆
- 配有双金属的热传感器用于电机过热保护
- 泄漏传感器可持续检测电机腔体是否进水，除了以下型号：  
DPK.x.x.075.x.x  
DPK.x.x.15.x.x  
DPK.x.x.22.x.x  
DPK.x.x.37.x.x
- 球墨铸铁叶轮具有高稳定性
- 双机封(SiC-SiC)可用于重载条件
- 高效电机使其具有高稳定性和低运行成本

## 运行条件

DWK/DPK可用于连续运行S1，和间歇运行S3。



图4. DPK在S1/S3运行时的液位

TM04-4094-0709

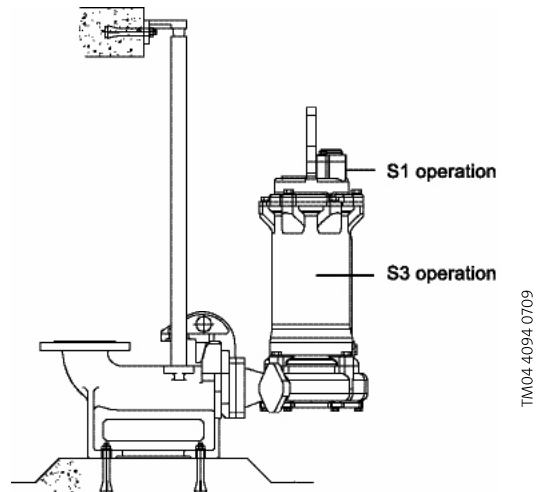
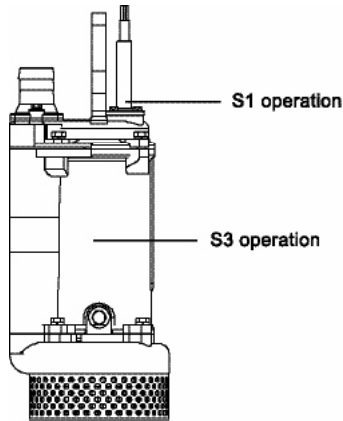

TM04 4144 0709

图5. DWK在S1/S3运行时的液位

### 连续运行

连续运行S1时液位需完全淹没电机顶部。

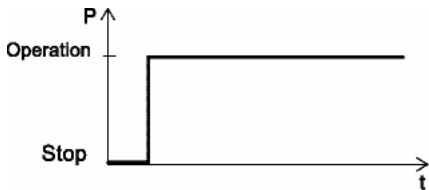

TM02 7775 4003

图6. 连续运行

### 间歇运行

当间歇运行S3时，水泵最多运行4分钟，停机最少6分钟。水泵必须部分淹没在泵送液体中，即液位高度至少应该达到电机外壳的中部。

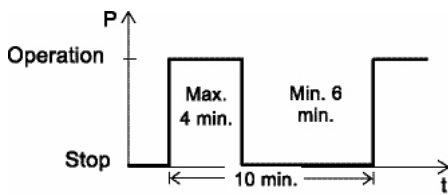

TM04 2656 2808

图7. 间歇运行

### 最大启停次数

DPK/DWK.O: 30次/小时

DWK.E: 18次/小时

## 型号说明

### DWK

例:	DWK .O .6 .50 .075 .S .5 .0D R
DWK	格兰富工程排水泵
O	半开式叶轮
E	闭式叶轮
	滤网孔径:
6	最大固体颗粒大小(mm)
50	泵名义出口直径(mm)
075	*轴功率P2/10(kW)
—	标准
S	带传感器(仅0.75~3.7kW)
	频率
5	50Hz
6	60Hz
	电压和启动方式
0D	380-415V,DOL
1D	380-415V,Y/D
0E	220-240V,DOL
1E	220-240V,Y/D
	材质
[ ]	标准
R	铸铁泵壳, 高铬不锈钢叶轮, 入口过滤网

\* 除了075=0.75kW

注: 不是所有泵都有任意变型产品。

### DPK

例:	DPK .10 .50 .075 .S .5 .0D
DPK	格兰富排水泵
	自由口径:
10	最大固体颗粒大小(mm)
50	泵名义出口直径(mm)
075	*轴功率P2/10(kW)
—	标准
S	带传感器(仅0.75~3.7kW)
	频率
5	50Hz
6	60Hz
	电压和启动方式
0D	380-415V,DOL
1D	380-415V,Y/D
0E	220-240V,DOL
1E	220-240V,Y/D

\* 除了075=0.75kW

注: 不是所有泵都有任意变型产品。

## 变型产品列表

### 电机

电缆长度-15m/25m/30m	联系格兰富
特殊电机	绝缘等级H 特殊电压
电机保护	密封传感器 传感器设置1-1 x Pt100低位轴承和1 x Pt100电机绕组
材质	叶轮-不锈钢 泵壳-不锈钢
出口	法兰: DIN, JIS, ANSI 软管: Storz (DWK)
测试	
标准叶轮下的特殊工作点测试	
全性能试验	
其他测试标准	联系格兰富
见证测试	
其他非标产品	联系格兰富

## 主要部件材质表

部 件	材 质		
	DIN	ASTM	KS
法兰	GG20	A48-CL30	GC200
软管连接	GG20	A48-CL30	GC200
叶轮	-GGG20/ Hi-Cr	-	GCD450/ Hi-Cr
泵壳	GG20	A48-CL30	GC200
电机壳	GG20	A48-CL30	GC200
入口滤网/环座	-	A283-Gr.D	SS400
电机顶盖	GG20	A48-CL30	GC200
机械密封腔	GG20	A48-CL30	GC200
转子/轴	-	ANSI410	STS410
电缆	2RNCT	2RNCT	2RNCT
吊环	1.4301	A276-304	STS304

DPK性能曲线 (50Hz)

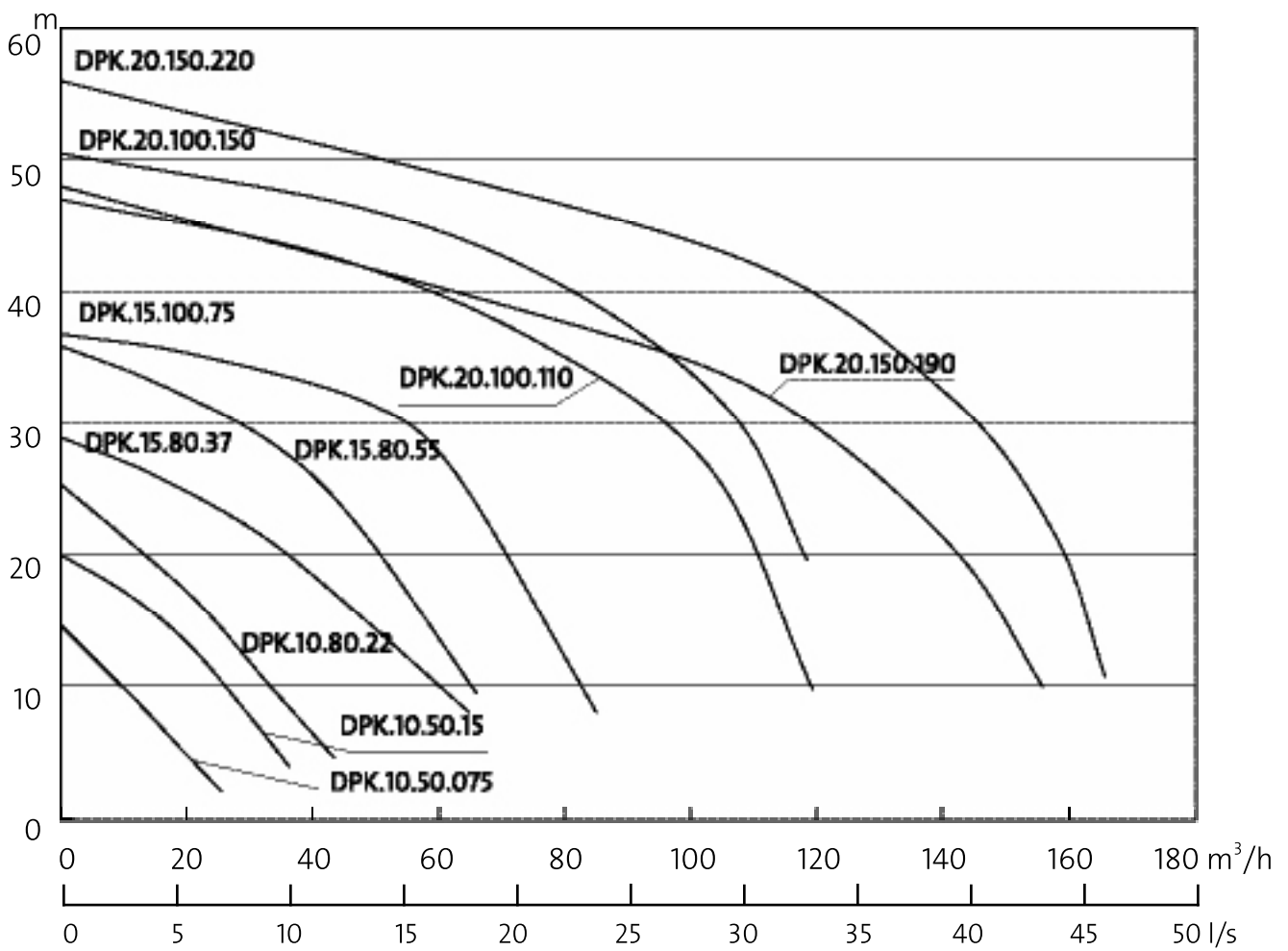

DWK.E性能曲线(50Hz)

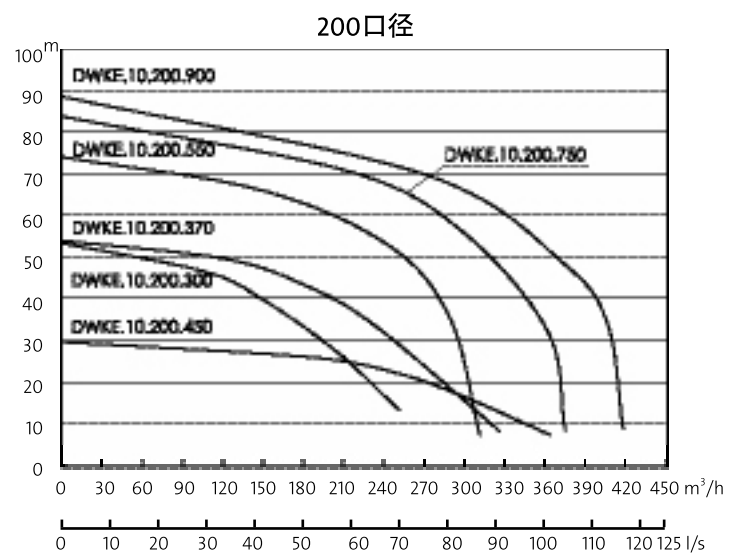
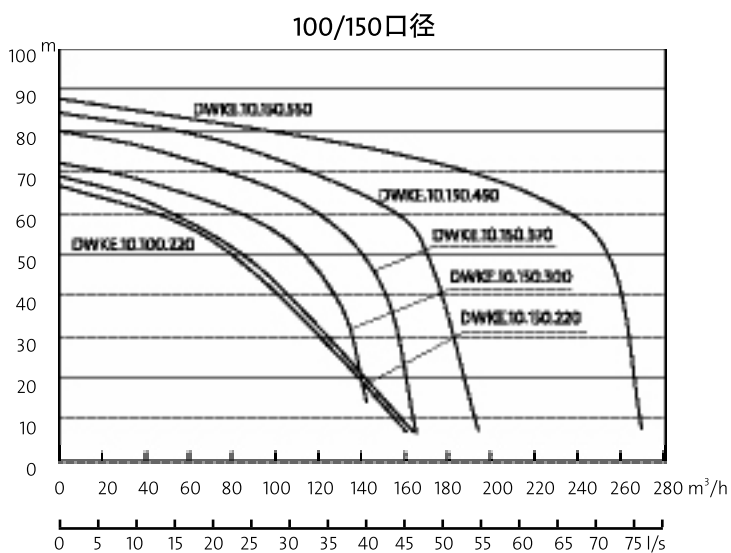



DWK.O性能曲线(50Hz)

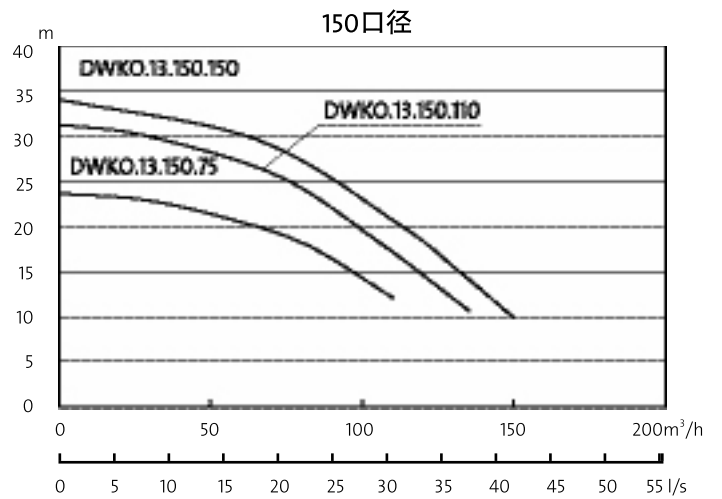
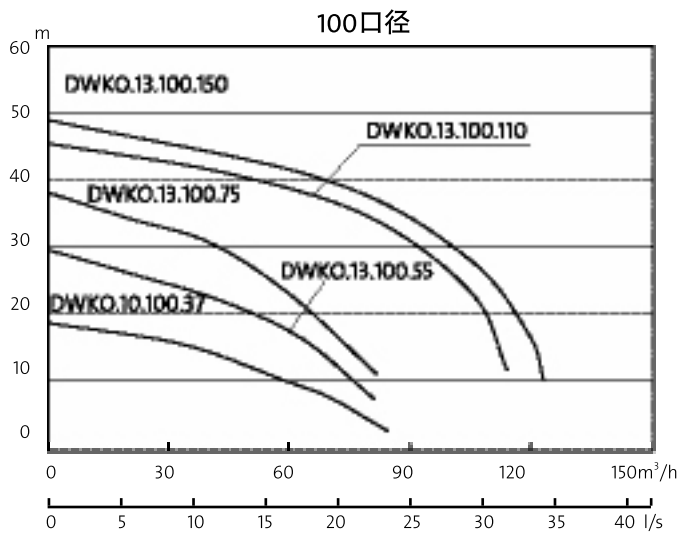
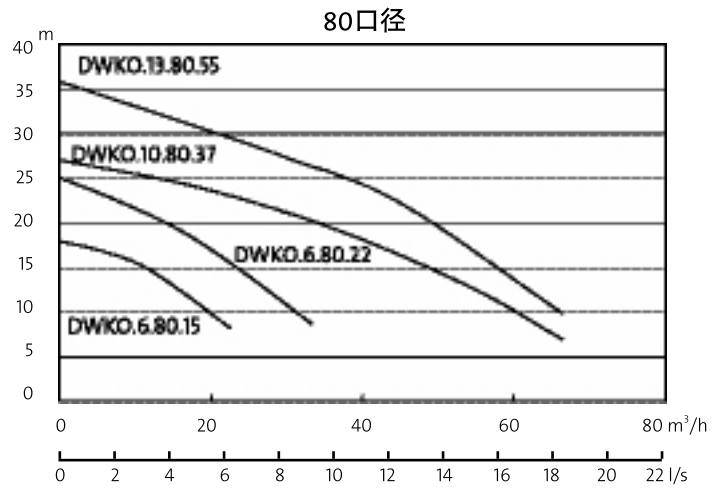
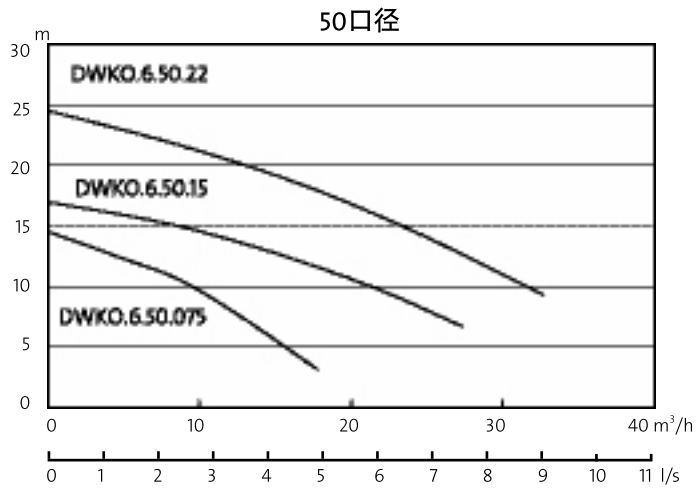

## DPK尺寸

DIM. NO.	DPK:10.50.075	DPK:10.50.115	DPK:10.80.22	DPK:15.80.37	DPK:15.80.55	DPK:15.100.75	DPK:20.100.110	DPK:20.100.150	DPK:20.150.190	DPK:20.150.220
Fig. 1			60Hz							
1	436	466	486	491	802	802	856	856	1026	1026
2	224	224	244	247	378	378	378	378	483	483
3	88	88	88	103	141	141	141	141	189	189
4	125	125	145	145	220	220	220	220	280	280
5	213	213	213	230	325	325	325	325	416	416
6	47	47	47	53	72	72	72	72	113	113
7	48	48	48	48	72	72	90	90	108	108
8	50	50	80	80	100	100	100	100	150	150
Fig. 2										
1	450	480	500	506	749	749	796	796	1163	1163
2	231	231	299	306	386	386	386	386	578	578
3	201	201	259	266	311	311	311	311	427	427
4	70	70	70	70	100	100	100	100	140	140
5	223	223	224	224	350	350	350	350	415	415
6	327	327	408	409	572	572	572	572	713	713
7	377	377	466	467	625	625	625	625	780	780
8	50	50	80	80	100	100	100	100	150	150
9	100	100	127	127	155	155	155	155	215	215
10	238	238	238	240	359	359	359	359	434	434
Fig. 3										
1	224	224	244	247	378	378	378	378	483	483
2	213	213	213	230	325	325	325	325	416	416
3	380	410	430	436	649	649	696	696	1026	1026
4	120	120	130	130	150	150	150	150	226	226
5	70	70	90	90	90	90	90	90	150	150
6	120	120	200	200	200	200	200	200	300	300
7	549	549	662	665	868	868	868	868	1083	1083
8	381	381	441	444	588	588	588	588	743	743
9	282	282	342	342	430	430	430	430	540	540
10	50	50	75	75	75	75	75	75	90	90
11	25A	25A	25A	25A	32A	32A	32A	32A	40A	40A
12	597	627	647	646	991	991	1045	1045	1240	1240
13	161	161	161	155	189	189	189	189	217	217
14	50	50	50	50	50	50	50	50	80	80
15	28	28	46	46	51	51	51	51	65	65
16	140	140	200	200	250	250	250	250	290	290
17	250	250	250	250	350	350	350	350	450	450
18	4	4	4	4	4	4	4	4	4	4
ZM	M16 x 200L	M16 x 200L	M16 x 200L	M16 x 200L	M16 x 200L	M16 x 200L	M16 x 200L	M16 x 200L	M20 x 200L	M20 x 200L

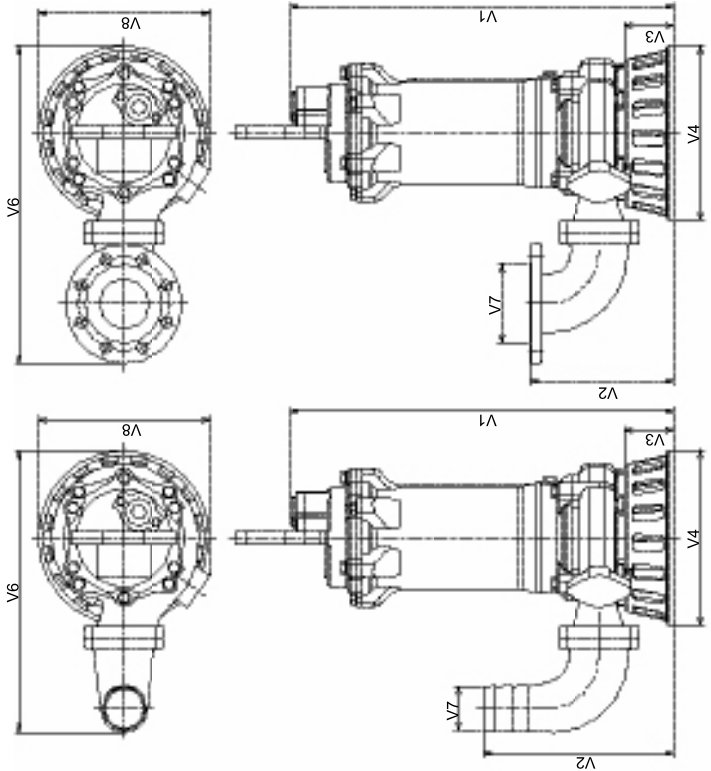

Fig.2 软管连接/法兰连接

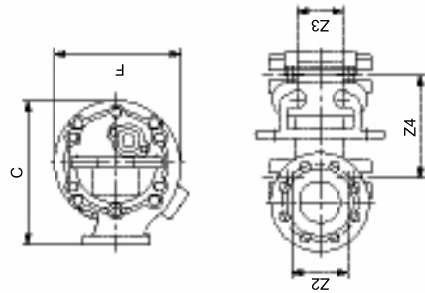

Fig.3 自耦连接

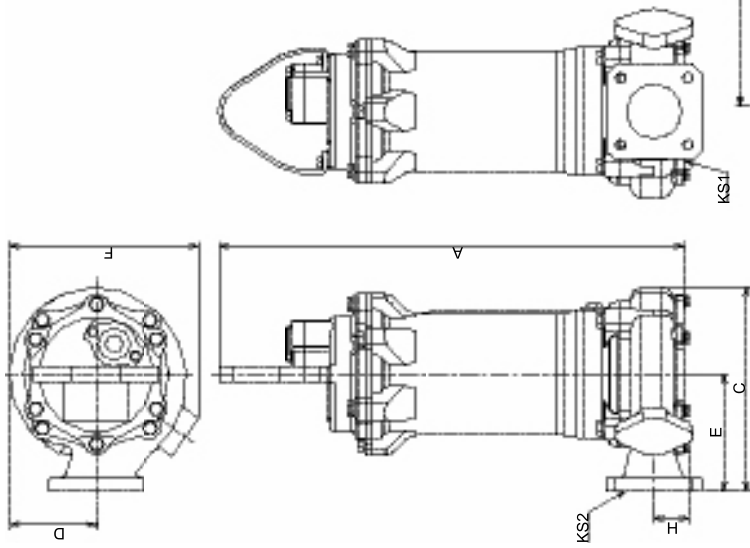
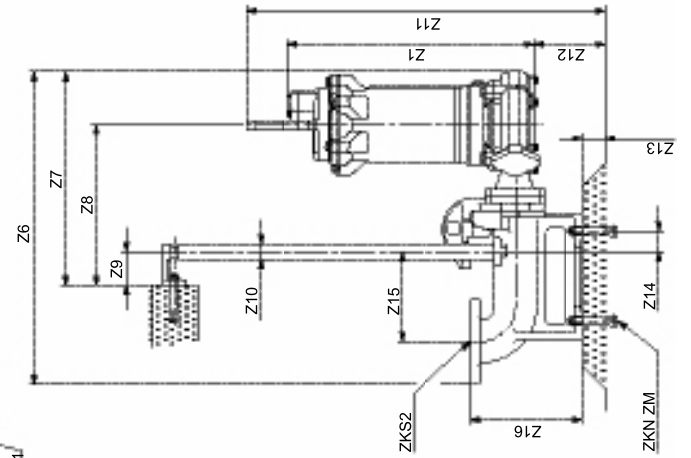

Fig.1 无连接



## DWK.O尺寸

DIM. NO.	DWK.50.075	DWK.50.15	DWK.80.15	DWK.50.22	DWK.80.22	DWK.100.37	DWK.80.55	DWK.100.55	DWK.150.75	DWK.100.110	DWK.150.110	DWK.100.150	DWK.150.150
<b>软管连接</b>													
1	398	428	428	448	448	591	591	734	734	734	779	779	779
2	50	50	80	50	80	100	75	100	100	150	150	100	100
3	65	65	65	65	65	90	90	116	116	116	116	116	116
4	231	231	231	231	231	286	286	353	353	353	353	353	353
5	202	202	202	202	202	234	234	302	302	302	302	302	302
6	459	489	557	509	577	686	706	829	849	900	894	894	945
7	448	478	478	498	498	680	680	-	-	-	-	-	-
8	110	110	110	110	110	134	134	177	177	177	177	177	177
9	213	213	213	213	213	253	253	323	323	323	323	323	323
<b>法兰连接</b>													
1	398	428	428	448	448	591	591	734	734	734	779	779	779
2	100	100	127	100	127	100	75	100	100	215	215	100	215
3	65	65	65	65	65	90	90	116	116	116	116	116	116
4	270	270	285	270	285	314	326	381	393	429	393	429	429
5	202	202	202	202	202	234	234	302	302	302	302	302	302
6	487	517	517	537	537	726	726	869	869	861	914	906	906
7	448	478	478	498	498	680	680	-	-	-	-	-	-
8	110	110	110	110	110	134	134	177	177	177	177	177	177
9	213	213	213	213	213	253	253	323	323	323	323	323	323

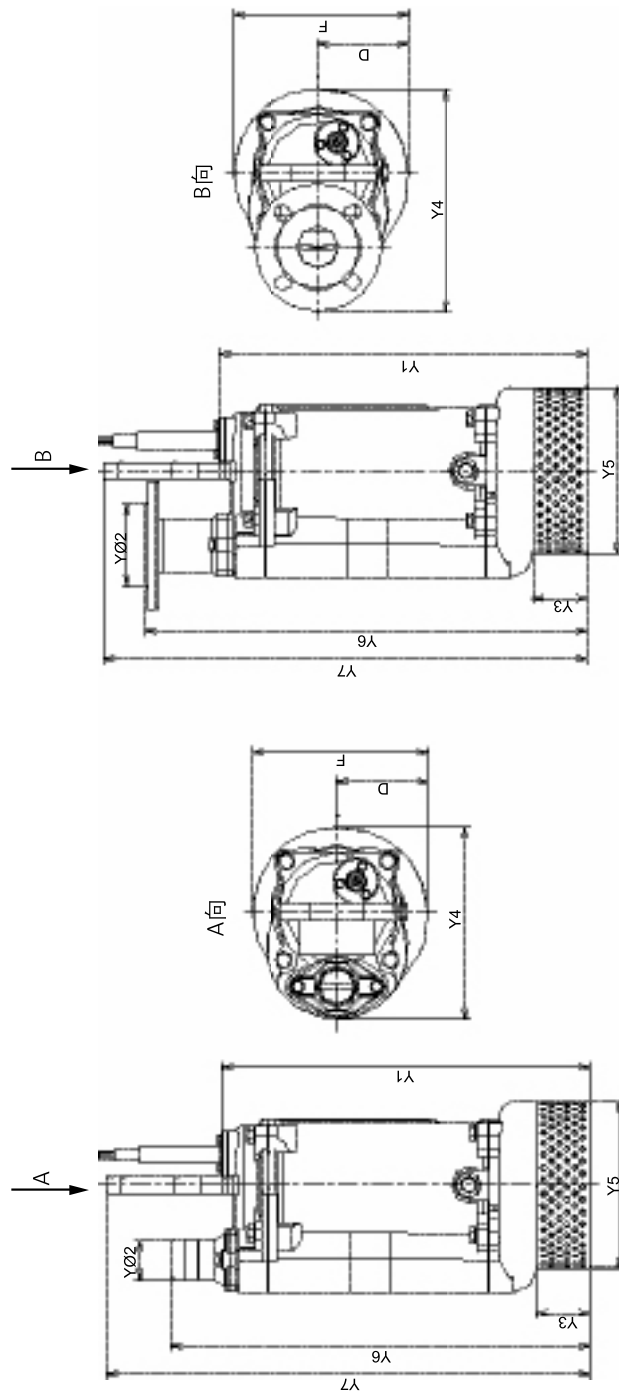
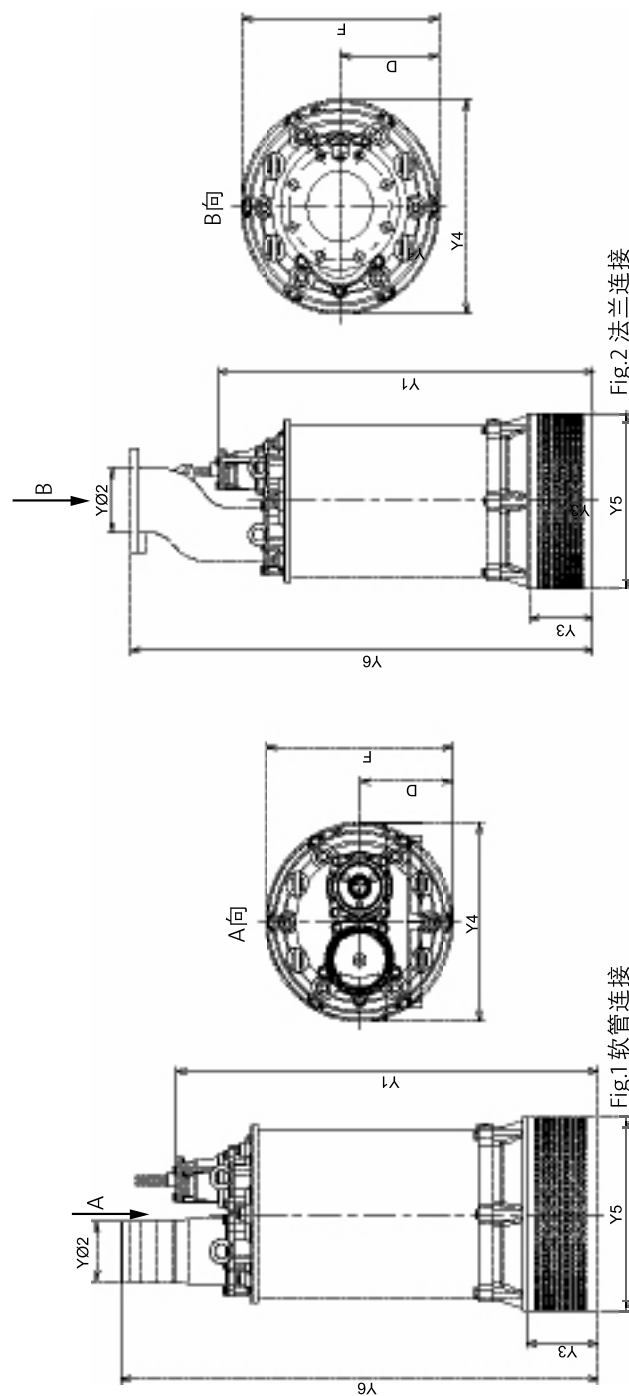

Fig.2 法兰连接

Fig.1 软管连接

## DWK.E尺寸

DIM. NO.	DWK.100.220	DWK.150.220	DWK.200.300	DWK.150.370	DWK.200.370	DWK.150.450	DWK.200.450	DWK.150.550	DWK.200.550	DWK.150.750	DWK.200.750	DWK.200.900
Fig. 1 软管连接												
1	1099	1099	1099	1099	1318	1318	1318	1418	1418	1418	1418	1418
2	100	150	200	200	200	150	200	200	200	200	200	200
3	183	183	183	183	220	220	220	220	220	220	220	220
4	470	470	470	470	612	612	612	612	612	612	612	612
5	470	470	470	470	557	557	557	557	557	557	557	557
6	1117	1232	1232	1192	1411	1411	1411	1511	1511	1511	1511	1511
8	235	235	235	235	306	306	306	306	306	306	306	306
9	470	470	470	470	612	612	612	612	612	612	612	612
Fig. 2 法兰连接												
1	1099	1099	1099	1099	1318	1318	1318	1418	1418	1418	1418	1418
2	100	150	200	200	200	150	200	200	200	200	200	200
3	183	183	183	183	220	220	220	220	220	220	220	220
4	470	470	470	470	612	612	612	612	612	612	612	612
5	470	470	470	470	557	557	557	557	557	557	557	557
6	1342	1342	1342	1342	1561	1561	1561	1661	1661	1661	1661	1661
8	235	235	235	235	306	306	306	306	306	306	306	306
9	470	470	470	470	612	612	612	612	612	612	612	612





## DPK附件

描述	尺寸	DPK [kW]										产品编码	
		0.75	1.5	2.2	3.7	5.5	7.5	11	15	19	22		
带卸扣的提升链, 镀锌	10 m	X	X	X	X	X	X	X	X			96884370	
	6 m	X	X	X	X	X	X	X	X			96884371	
	3 m	X	X	X	X	X	X	X	X			96884372	
带夹子的金属线, 镀锌	10 m										X	X	96884373
	6 m										X	X	96884374
	3 m										X	X	96884375
橡胶软管10m	50 mm	X	X										96922543
	80 mm			X	X	X							96922544
	100 mm						X	X	X				96922545
	150 mm										X	X	96922546
橡胶软管20m	50 mm	X	X										96922548
	80 mm			X	X	X							96922549
	100 mm						X	X	X				96922550
	150 mm										X	X	96922551
出口弯管, JIS法兰, 含连接件													
50 mm	垫圈 50 mm	X	X										96922605
	螺钉 4 x M10 x 30 mm												
	垫片 4 x M10												
80 mm	垫圈 80 mm											96922606	
	螺钉 4 x M12 x 35 mm												
	垫片 4 x M12												
100 mm	垫圈 100 mm											96922607	
	螺钉 4 x M12 x 40 mm												
	垫片 4 x M12												
150 mm	垫圈 150 mm											96922608	
	螺钉 4 x M12 x 40 mm												
	垫片 4 x M12												
出口弯管, DIN法兰, 含连接件													
50 mm	垫圈 50 mm	X	X										96922609
	螺钉 4 x M10 x 30 mm												
	垫片 4 x M10												
80 mm	垫圈 80 mm											96922610	
	螺钉 4 x M12 x 35 mm												
	垫片 4 x M12												
100 mm	垫圈 100 mm											96922611	
	螺钉 4 x M12 x 40 mm												
	垫片 4 x M12												
150 mm	垫圈 150 mm											96922612	
	螺钉 4 x M12 x 40 mm												
	垫片 4 x M12												
出口弯管, ANSI法兰, 含连接件													
2"	垫圈 2"	X	X										96922613
	螺钉 4 x M10 x 30 mm												
	垫片 4 x M10												
3"	垫圈 3"											96922614	
	螺钉 4 x M12 x 35 mm												
	垫片 4 x M12												
4"	垫圈 4"											96922615	
	螺钉 4 x M12 x 40 mm												
	垫片 4 x M12												
6"	垫圈 6"											96922616	
	螺钉 4 x M12 x 40 mm												
	垫片 4 x M12												

描述	尺寸	DPK [kW]										产品编码
		0.75	1.5	2.2	3.7	5.5	7.5	11	15	19	22	
<b>出口弯管, 软管连接, 含软管接头</b>												
50 mm	垫圈	50 mm	X	X								96922617
	螺钉	4 x M10 x 30 mm										
	垫片	4 x M10										
80 mm	垫圈	80 mm			X	X	X					96922618
	螺钉	4 x M12 x 35 mm										
	垫片	4 x M12										
100 mm	垫圈	100 mm					X	X	X			96922619
	螺钉	4 x M12 x 40 mm										
	垫片	4 x M12										
150 mm	垫圈	150 mm								X	X	96922620
	螺钉	4 x M12 x 40 mm										
	垫片	4 x M12										
	螺母	M12										
<b>自动耦合系统(ADC-T), JIS法兰, 不含地脚螺栓, 导轨提升链等</b>												
50 mm			X	X								96922621
80 mm					X	X	X					96922622
100 mm							X	X	X			96922623
150 mm										X	X	96922624
<b>自动耦合系统(ADC-T), DIN法兰, 不含地脚螺栓, 导轨提升链等</b>												
50 mm			X	X								96922625
80 mm					X	X	X					96936832
100 mm							X	X	X			96922627
150 mm										X	X	96922628
<b>自动耦合系统(ADC-T), ANSI法兰, 不含地脚螺栓, 导轨提升链等</b>												
2"			X	X								96922629
3"					X	X	X					96922630
4"							X	X	X			96922631
5"										X	X	96922632
密封圈	50 mm		X	X								96936839
	80 mm				X	X	X					96936840
	100 mm						X	X	X			96936841
	150 mm									X	X	96936842
地脚螺栓(用于自动耦合装置)	4 x M16 x 200 mm 50 mm		X	X								96922633
	4 x M16 x 200 mm 80 mm				X	X	X					96922634
	4 x M16 x 200 mm 100 mm						X	X	X			96922635
	4 x M20 x 200 mm 150 mm									X	X	96922636
控制器	GU01		X	X	X	X	X	X	X	X	X	96922603
	GU02					X	X	X	X	X	X	96922604
<b>环座, 含螺钉和垫片</b>												
50mm	螺钉	3 x M8 x 35 mm			X							96936843
	垫片	3 x M8										
100mm	螺钉	3 x M12 x 45 mm				X	X	X	X			96936844
	垫片	3 x M12										
150mm	螺钉	3 x M12 x 40 mm								X	X	96936845
	垫片	3 x M12										

## DWK附件

描述	尺寸	DWK.O [kW]								DWK.E [kW]								产品编码
		0.75	1.5	2.2	3.7	5.5	7.5	11	15	22	30	37	45	55	75	90		
带卸扣的提升链, 镀锌钢	10 m	X	X	X	X	X	X	X	X								96884370	
	6 m	X	X	X	X	X	X	X	X								96884371	
	3 m	X	X	X	X	X	X	X	X								96884372	
带夹子的金属线, 镀锌	10 m									X	X	X	X	X	X	X	96884373	
	6 m									X	X	X	X	X	X	X	96884374	
	3 m									X	X	X	X	X	X	X	96884375	
<b>半耦合, Storz连接</b>																		
50 mm	O型圈	Ø3.1 x Ø60															96884376	
	螺钉	4 x M8 x 30 mm	X	X	X													
	垫片	4 x M8																
80 mm	O型圈	Ø3.1 x Ø60															96884377	
	螺钉	4 x M8 x 30 mm		X	X													
	垫片	4 x M8																
80 mm	O型圈	Ø3.1 x Ø105															96884378	
	螺钉	4 x M10 x 30 mm				X	X											
	垫片	4 x M10																
100 mm	O型圈	Ø3.1 x Ø105															96884379	
	螺钉	4 x M10 x 30 mm				X	X	X	X									
	垫片	4 x M10																
150 mm	O型圈	Ø3.1 x Ø105															96884380	
	螺钉	4 x M10 x 30 mm						X	X	X								
	垫片	4 x M10																
100 mm	O型圈	Ø3.5 x Ø150									X						96884381	
	螺钉	5 x M12 x 35 mm																
	垫片	5 x M12																
150 mm	O型圈	Ø3.1 x Ø158									X	X					96884382	
	螺钉	5 x M12 x 35 mm																
	垫片	5 x M12																
150 mm	O型圈	Ø5.7 x Ø180										X	X				96884383	
	螺钉	6 x M16 x 45 mm																
	垫片	6 x M16																
150 mm	O型圈	Ø5.7 x Ø180													X		96884384	
	螺钉	6 x M16 x 55 mm																
	垫片	6 x M16																
200 mm	O型圈	Ø5.7 x Ø180										X					96884385	
	螺钉	5 x M12 x 35 mm																
	垫片	5 x M12																
200 mm	O型圈	Ø5.7 x Ø180										X	X				96884386	
	螺钉	6 x M16 x 45 mm																
	垫片	6 x M16																
200 mm	O型圈	Ø5.7 x Ø180													X	X	96922516	
	螺钉	6 x M16 x 55 mm																
	垫片	6 x M16																
<b>10m扁平软管, 含Storz接口</b>																		
50 mm		X	X	X													96922517	
80 mm			X	X	X	X											96922518	
100 mm					X	X	X	X	X								96922520	
150 mm							X	X	X	X	X	X	X	X			96922521	
200 mm											X	X	X	X	X	X	96922528	
<b>20m扁平软管, 含Storz接口</b>																		
50 mm		X	X	X													96922529	
80 mm			X	X	X	X											96922530	
100 mm					X	X	X	X	X								96922532	
150 mm							X	X	X	X	X	X	X	X			96922533	
200 mm											X	X	X	X	X	X	96922540	

描述	尺寸	DWK.O [kW]							DWK.E [kW]							产品编码
		0.75	1.5	2.2	3.7	5.5	7.5	11	15	22	30	37	45	55	75	
任意长度软管（按m计算，只有8”），含Storz接口																
	200 mm											X	X			
	200 mm													X	X	X
10m橡胶管，含Storz接口																
橡胶管10m	50 mm	X	X	X												96922543
	80 mm		X	X	X	X										96922544
	100 mm				X	X	X	X	X	X						96922545
	150 mm						X	X	X	X	X	X	X			96922546
	200 mm											X	X	X	X	X
20m橡胶管，含Storz接口																
橡胶管20m	50 mm	X	X	X												96922548
	80 mm		X	X	X	X										96922549
	100 mm				X	X	X	X	X	X						96922550
	150 mm						X	X	X	X	X	X	X			96922551
	200 mm											X	X	X	X	X
任意长度橡胶管（按m计算，只有8”），含Storz接口																
	200 mm											X	X			
	200 mm													X	X	X
出口法兰，JIS，含连接件																
50 mm	O型圈	Ø3.1 x Ø60														
	螺钉	4 x M8 x 30 mm	X	X	X											96922555
	垫片	4 x M8														
80 mm	O型圈	Ø3.1 x Ø60														
	螺钉	4 x M8 x 30 mm		X	X											96922556
	垫片	4 x M8														
80 mm	O型圈	Ø3.1 x Ø105														
	螺钉	4 x M10 x 30 mm				X	X									96922557
	垫片	4 x M10														
100 mm	O型圈	Ø3.1 x Ø105														
	螺钉	4 x M10 x 30 mm				X	X	X	X	X						96922558
	垫片	4 x M10														
150 mm	O型圈	Ø3.1 x Ø105														
	螺钉	4 x M10 x 30 mm						X	X	X						96922559
	垫片	4 x M10														
100 mm	垫圈	150														
	螺钉	5 x M12 x 35 mm								X						96922560
	垫片	5 x M12														
150 mm	垫圈	150														
	螺钉	5 x M12 x 35 mm								X	X					96922561
	垫片	5 x M12														
150 mm	垫圈	150														
	螺钉	6 x M16 x 45 mm										X	X			96922562
	垫片	6 x M16														
150 mm	垫圈	150														
	螺钉	6 x M16 x 55 mm												X		96922563
	垫片	6 x M16														
200 mm	垫圈	150														
	螺钉	5 x M12 x 35 mm									X					96922564
	垫片	5 x M12														
200 mm	垫圈	150														
	螺钉	6 x M16 x 45 mm										X	X			96922565
	垫片	6 x M16														
200 mm	垫圈	150														
	螺钉	6 x M16 x 55 mm												X	X	X
	垫片	16 x M6														96922566

描述	尺寸	DWK.O [kW]								DWK.E [kW]							产品编码													
		0.75	1.5	2.2	3.7	5.5	7.5	11	15	22	30	37	45	55	75	90														
<b>出口法兰, DIN, 含连接件</b>																														
50 mm	O型圈	Ø3.1 x Ø60															X	X	X											96922567
	螺钉	4 x M8 x 30 mm																												
	垫片	4 x M8																												
80 mm	O型圈	Ø3.1 x Ø60																X	X										96922568	
	螺钉	4 x M8 x 30 mm																												
	垫片	4 x M8																												
80 mm	O型圈	Ø3.1 x Ø105																		X	X								96922569	
	螺钉	4 x M10 x 30 mm																												
	垫片	4 x M10																												
100 mm	O型圈	Ø3.1 x Ø105																		X	X	X	X	X					96922570	
	螺钉	4 x M10 x 30 mm																												
	垫片	4 x M10																												
150 mm	O型圈	Ø3.1 x Ø105																			X	X	X						96922571	
	螺钉	4 x M10 x 30 mm																												
	垫片	4 x M10																												
100 mm	垫圈	150																										96922572		
	螺钉	5 x M12 x 35 mm																												
	垫片	5 x M12																												
150 mm	垫圈	150																			X	X							96922573	
	螺钉	5 x M12 x 35 mm																												
	垫片	5 x M12																												
150 mm	垫圈	150																					X	X					96922574	
	螺钉	6 x M16 x 45 mm																												
	垫片	6 x M16																												
150 mm	垫圈	150																						X					96922575	
	螺钉	6 x M16 x 55 mm																												
	垫片	6 x M16																												
200 mm	垫圈	150																										96922576		
	螺钉	5 x M12 x 35 mm																												
	垫片	5 x M12																												
200 mm	垫圈	150																							X	X			96922577	
	螺钉	6 x M16 x 45 mm																												
	垫片	6 x M16																												
200 mm	垫圈	150																							X	X	X		96922578	
	螺钉	6 x M16 x 55 mm																												
	垫片	6 x M16																												
<b>出口法兰, ANSI, 含连接件</b>																														
2"	O型圈	Ø3.1 x Ø60															X	X	X											96922579
	螺钉	4 x M8 x 30 mm																												
	垫片	4 x M8																												
3"	O型圈	Ø3.1 x Ø60																X	X											96922580
	螺钉	4 x M8 x 30 mm																												
	垫片	4 x M8																												
3"	O型圈	Ø3.1 x Ø105																		X	X								96922581	
	螺钉	4 x M10 x 30 mm																												
	垫片	4 x M10																												
4"	O型圈	Ø3.1 x Ø105																		X	X	X	X	X					96922582	
	螺钉	4 x M10 x 30 mm																												
	垫片	4 x M10																												
6"	O型圈	Ø3.1 x Ø105																			X	X	X						96922583	
	螺钉	4 x M10 x 30 mm																												
	垫片	10																												
4"	O型圈	150																						X					96922584	
	螺钉	5 x M12 x 35 mm																												
	垫片	5 x M12																												
6"	O型圈	150																					X	X					96922585	
	螺钉	5 x M12 x 35 mm																												
	垫片	5 x M12																												



描述	尺寸	DWK.O [kW]								DWK.E [kW]							产品编码
		0.75	1.5	2.2	3.7	5.5	7.5	11	15	22	30	37	45	55	75	90	
6"	垫圈	150															
	螺钉	6 x M16 x 45 mm										X	X				
	垫片	6 x M16															
6"	垫圈	150															
	螺钉	6 x M16 x 55 mm												X			
	垫片	6 x M16															
8"	垫圈	150															
	螺钉	5 x M12 x 35 mm									X						
	垫片	5 x M12															
8"	垫圈	150															
	螺钉	6 x M16 x 45 mm										X	X				
	垫片	6 x M16															
8"	垫圈	150															
	螺钉	6 x M16 x 55 mm												X	X	X	
	垫片	6 x M16															
<b>软管连接, 含软管接头</b>																	
50 mm	O型圈	Ø3.1 x Ø60															
	螺钉	4 x M8 x 30 mm	X	X	X												
	垫片	4 x M8															
80 mm	O型圈	Ø3.1 x Ø60															
	螺钉	4 x M8 x 30 mm		X	X												
	垫片	4 x M8															
80 mm	O型圈	Ø3.1 x Ø105															
	螺钉	4 x M10 x 30 mm				X	X										
	垫片	4 x M10															
100 mm	O型圈	Ø3.1 x Ø105															
	螺钉	4 x M10 x 30 mm				X	X	X	X	X							
	垫片	4 x M10															
150 mm	O型圈	Ø3.1 x Ø105															
	螺钉	4 x M10 x 30 mm						X	X	X							
	垫片	4 x M10															
100 mm	O型圈	Ø3.5 x Ø150															
	螺钉	5 x M12 x 35 mm									X						
	垫片	5 x M12															
150 mm	O型圈	Ø3.1 x Ø158															
	螺钉	5 x M12 x 35 mm									X	X					
	垫片	5 x M12															
150 mm	O型圈	Ø5.7 x Ø180															
	螺钉	6 x M16 x 45 mm										X	X				
	垫片	6 x M16															
150 mm	O型圈	Ø5.7 x Ø180															
	螺钉	6 x M16 x 55 mm												X			
	垫片	6 x M16															
200 mm	O型圈	Ø5.7 x Ø180															
	螺钉	5 x M12 x 35 mm										X					
	垫片	5 x M12															
200 mm	O型圈	Ø5.7 x Ø180															
	螺钉	6 x M16 x 45 mm										X	X				
	垫片	6 x M16															
200 mm	O型圈	Ø5.7 x Ø180															
	螺钉	6 x M16 x 55 mm												X	X	X	
	垫片	6 x M16															
GU01		X	X	X	X	X	X	X	X	X	X	X	X	X	X	X	96922603
GU02					X	X	X	X	X	X	X	X	X	X	X	X	96922604